



12" Round Incandescent Look LED Bicycle Signals



Features / Benefits

- Uniform non-pixelated illumination with "incandescent look"
- 90% reduction in power consumption vs. incandescent
- Long life; up to 10 times longer than incandescent
- Expanded view light distribution pattern suitable for span wire and fixed wire
- Easy to install with existing signal enclosure

Specifications

- Operation temperature range: -40 °C to +74 °C
- Operation voltage from 80 to 135 VAC
- UV stabilized scratch resistant shell
- Fuse and transient suppressor incorporated for line and load protection

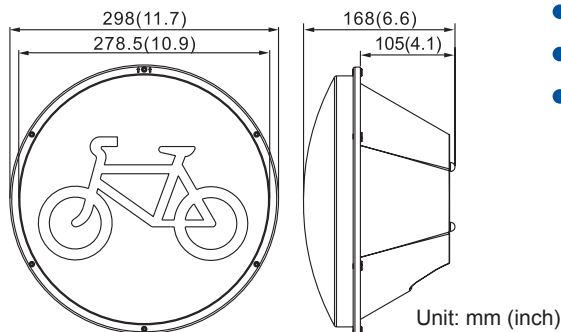

Model Number	Color	Dimension	Operation Voltage (VAC)	Power Consumption (Watt) (Typ.)	Dominant Wavelength (nm) (Typ.)	Peak Minimum Maintained Luminous Intensity (cd) (Min.)
TRB-R12SG-D2T-C	Red	12" / 300 mm	80 ~ 135	9	625	> 100
TRB-Y12SG-D1T-C	Yellow	12" / 300 mm	80 ~ 135	14.5	590	> 100
TRB-G12SG-D2T-C	Green	12" / 300 mm	80 ~ 135	8	500	> 100

Distributed by **FORTTRAN** www.forttrantraffic.com
 Central Office: 1-800-387-4555
 Western Office: 604-502-9680

